

Python i strojno učenje na resursu Supek

Kvakić, Marko

Educational content / Obrazovni sadržaj

Publication year / Godina izdavanja: **2023**

Permanent link / Trajna poveznica: <https://urn.nsk.hr/urn:nbn:hr:102:490687>

Rights / Prava: [Attribution 4.0 International](#)/[Imenovanje 4.0 međunarodna](#)

Download date / Datum preuzimanja: **2024-11-18**



Repository / Repozitorij:

[Digital repository of the University Computing Centre \(SRCE\)](#)





Python i strojno učenje na resursu Supek

Sveučilišni računski centar (Srce)

6. listopada 2023.



Projekt je sufinancirala
Europska unija iz Europskog
fonda za regionalni razvoj.



Sadržaj

- **Python i Lustre**
 - Python, pip i conda
 - Kako Lustre funkcionira?
- **Apptainer**
 - Uvod
 - Izgradnja na Supeku
 - Izvršavanje
- **Strojno učenje na Supeku**
 - Aplikacije i performanse
 - Način implementacije
- **Primjeri**



Projekt je sufinancirala
Europska unija iz Europskog
fonda za regionalni razvoj.



Python i Lustre



Europska unija
"Zajedno do fondova EU"



EUROPSKI STRUKTURNI
I INVESTICIJSKI FONDovi



Operativni program
KONKURENTNOST
I KOHEZIJA

Projekt je sufinancirala Europska unija iz
Europskog fonda za regionalni razvoj.

Python i Lustre

Python, pip i conda

- Bogat ekosistem
 - znanstveno računanje
 - podatkovna znanost
 - strojno učenje
- Instalacijski upravitelji
 - pip
 - python –m venv
 - conda
- Osiguravaju "bezbolnu" instalaciju knjižnica i ovisnosti

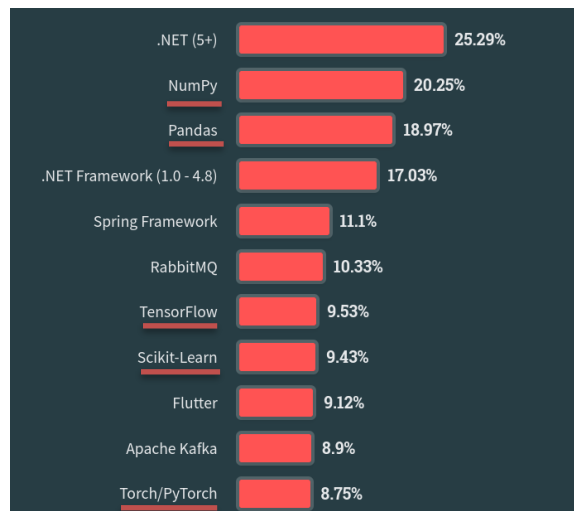

Slika 1 Rezultati Stack Overflow ankete iz 2023 ([izvor](#)) za najkorištenije programske jezike (gore) i 'ostala' programska sučelja (dolje).



Europska unija
"Zajedno do fondova EU"



EUROPSKI STRUKTURNI
I INVESTICIJSKI FONDovi



Operativni program
KONKURENTNOST
I KOHEZIJA

Projekt je sufinancirala Europska unija iz
Europskog fonda za regionalni razvoj.

Python i Lustre

Python, pip i conda

```
korisnik@kompjuter:~ python3 -m venv venv-dir

korisnik@kompjuter:~ source venv-dir/bin/activate

(venv-dir) korisnik@kompjuter:~ pip install numpy scipy pandas matplotlib
ipython
Collecting numpy
...
Successfully installed ...

(venv-dir) korisnik@kompjuter:~ pip list
Package            Version
-----
asttokens          2.4.0
backcall           0.2.0
contourpy          1.1.1
cyclor             0.11.0
decorator          5.1.1
...

(venv-dir) korisnik@kompjuter:~ python moja-skripta.py
...
```

- 1) Napravi virtualno okruženje **venv-dir**
- 2) Aktiviraj virtualno okruženje
- 3) Instaliraj knjižnice
- 4) Ispiši instalirane knjižnice
- 5) Izvrši skriptu python

Kod 1 Primjer instalacije knjižnica python korištenjem virtualnog okruženja



Europska unija
"Zajedno do fondova EU"



EUROPSKI STRUKTURNI
I INVESTICIJSKI FONDovi



Operativni program
KONKURENTNOST
I KOHEZIJA

Projekt je sufinancirala Europska unija iz
Europskog fonda za regionalni razvoj.

Python i Lustre

Python, pip i conda

```
korisnik@kompjuter:~ find venv-dir -type f | wc -l
13863

korisnik@kompjuter:~ find venv-dir -type d | wc -l
1325

korisnik@kompjuter:~ du -bs venv-dir
373471553 venv-dir

korisnik@kompjuter:~ find venv-dir -type f | xargs ls -sS | ls -sS
34304 venv-dir/lib/python3.9/site-packages/numpy.libs/libopenblas64_p-...
6436 venv-dir/lib/python3.9/site-packages/kiwisolver/_cext.cpython-39...
5576 venv-dir/lib/python3.9/site-packages/matplotlib/ft2font.cpython-...
3348 venv-dir/lib/python3.9/site-packages/matplotlib/backends/_backen...
2624 venv-dir/lib/python3.9/site-packages/numpy.libs/libgfortran-0400...
2364 venv-dir/lib/python3.9/site-packages/matplotlib/_image.cpython-3...
2348 venv-dir/lib/python3.9/site-packages/matplotlib/_qhull.cpython-3...
1780 venv-dir/lib/python3.9/site-packages/matplotlib/_path.cpython-39...
740 venv-dir/lib/python3.9/site-packages/matplotlib/mpl-data/fonts/t...
688 venv-dir/lib/python3.9/site-packages/matplotlib/mpl-data/fonts/t...
```

- 1) Broj datoteka u virtualnom okruženju
- 2) Broj direktorija u virtualnom okruženju
- 3) Veličina direktorija virtualnog okruženja
- 4) Ispiši 10 najvećih datoteka

Prosječna veličina = **28 kbytea**

Kod 2 Ispis značajke kreiranog virtualnog okruženja



Europska unija
"Zajedno do fondova EU"



EUROPSKI STRUKTURNI
I INVESTICIJSKI FONDOVI



Operativni program
KONKURENTNOST
I KOHEZIJA

Projekt je sufinancirala Europska unija iz
Europskog fonda za regionalni razvoj.

Python i Lustre

Kako Lustre funkcionira?

- Paralelni distribuirani datotečni sustav namijenjen HPC okruženju
- Odvajanje virtualnog od fizičkog zapisa raspodijeljenog na više poslužitelja
- Komponente
 - Management – usklađivanje
 - Metadata – virtualni zapis
 - Object Storage – stvarni zapis
 - Client – korisnik
 - Network – veza

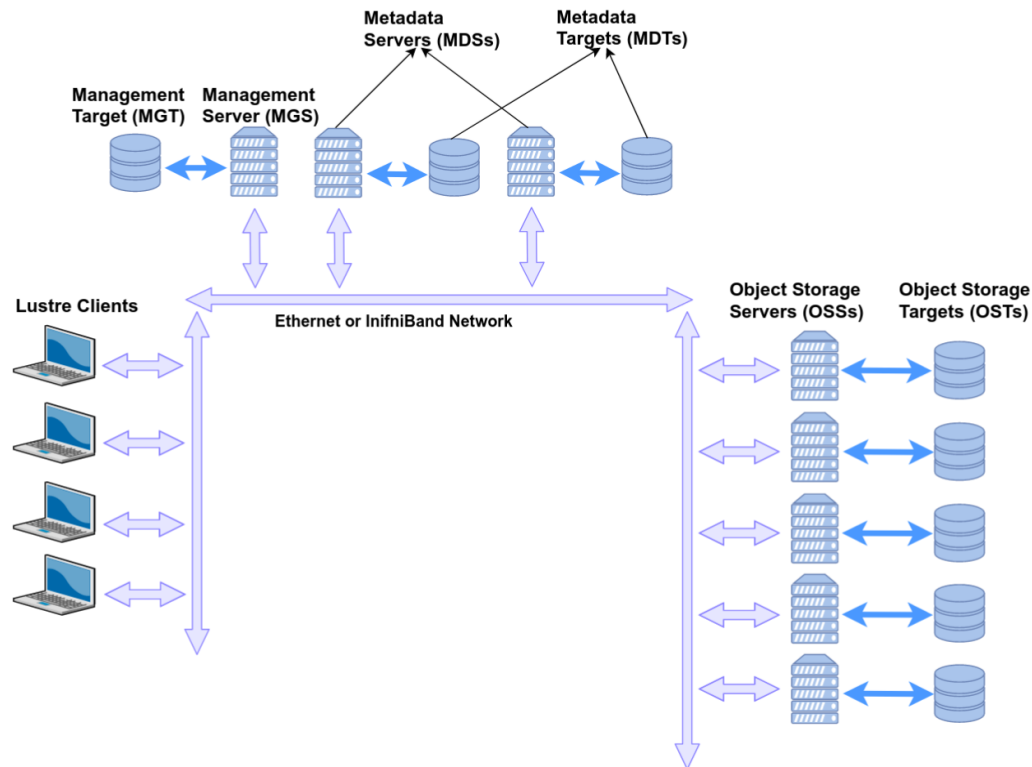

Slika 2 Shema datotečnog sustava Lustre (Figure 1 u [izvoru](#))



Europska unija
"Zajedno do fondova EU"



EUROPSKI STRUKTURNI
I INVESTICIJSKI FONDovi



Operativni program
KONKURENTNOST
I KOHEZIJA

Projekt je sufinancirala Europska unija iz
Europskog fonda za regionalni razvoj.



Python i Lustre

Lustre file striping

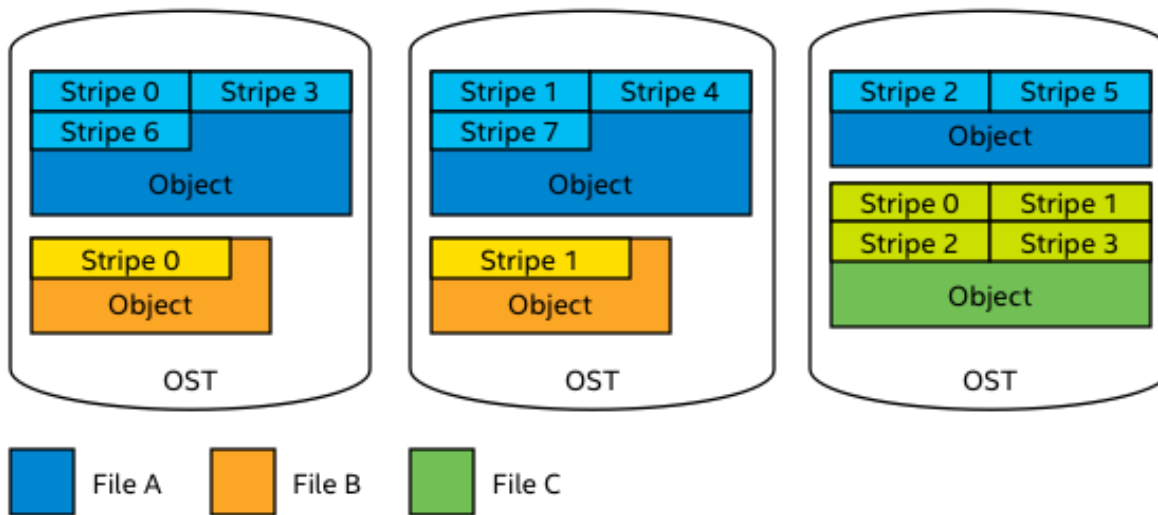

Slika 3 Shema file stripinga u Lustreu (Fig 1. u [izvoru](#))



Python i Lustre

Lustre performanse

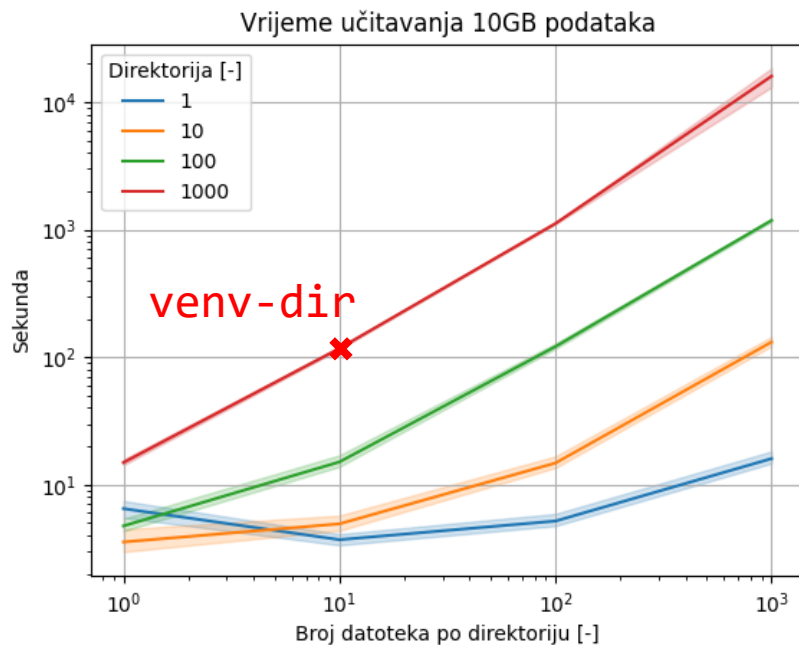

Slika 4 Performanse učitavanja 10GB podataka raspodijeljenih u 1-1000 direktorija i 1-1000 datoteka po direktoriju



Apptainer i kontejneri



Projekt je sufinancirala Europska unija iz
Europskog fonda za regionalni razvoj.

Apptainer i kontejneri

Uvod

- Kontejneri
 - izoliran skup datoteka koji sadrži sve ovisnosti potrebne za izvršavanje aplikacije
- Apptainer
 - prilagođeni HPC-u
- Svrha
 - stvaranje specifičnih okolina za određenu aplikaciju
 - najbolje za Python i R knjižnice



Slika 5 Apptainer logo



Apptainer i kontejneri

Izgradnja i korištenje na Supeku

- Izgradnja samo na pristupnom **gpu** poslužitelju
 - `/scratch/apptainer`
- MPI podrška
 - *bind model*
 - RedHat 8 kompatibilni OS
- GPU podrška
 - `--nv` opcija



Apptainer i kontejneri

Izrada i korištenje kontejnera

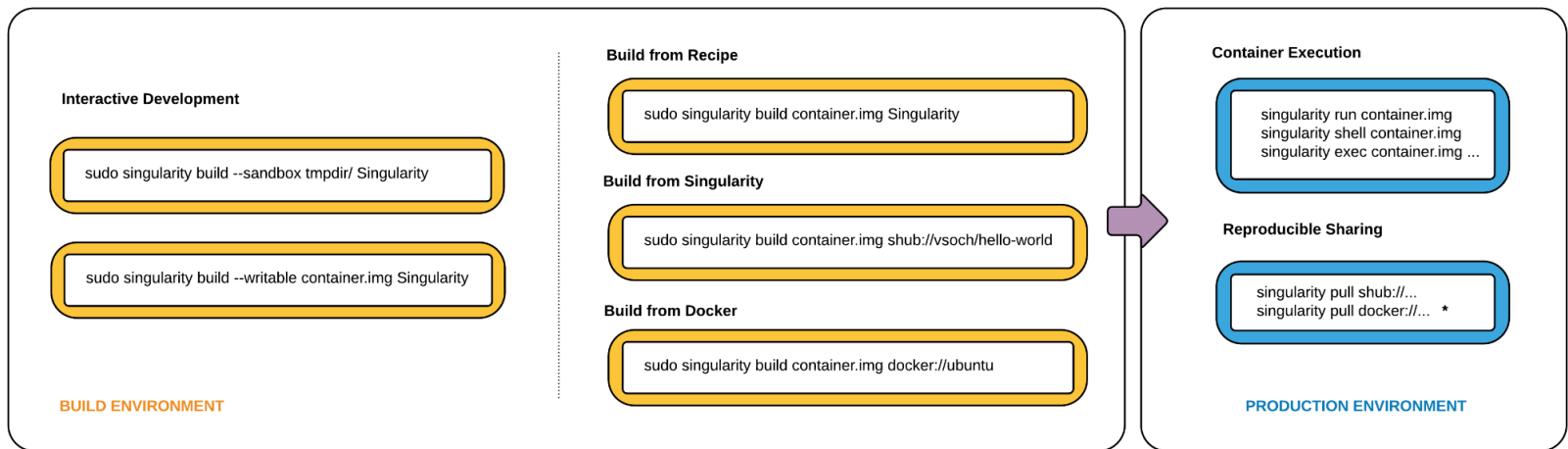

* Docker construction from layers not guaranteed to replicate between pulls

Slika 6 "Singularity flow" ([Izvor](#))

Apptainer i kontejneri

Izgradnja jednostavnog sandbox direktorija i konverzija

```
[korisnik@kompjuter ~]$ ssh korisnik@login-gpu.hpc.srce.hr
[korisnik@x3000c0s27b0n0 ~]$ cd /scratch/apptainer
[korisnik@x3000c0s27b0n0 apptainer]$ mkdir ${USER} && cd ${USER}

[korisnik@x3000c0s27b0n0 korisnik]$ apptainer build --sandbox pip/
docker://ubuntu:22.04
[korisnik@x3000c0s27b0n0 korisnik]$ apptainer shell --writable --fakeroot pip/

Apptainer> apt update -y
Apptainer> apt upgrade -y
...
Apptainer> apt install python3-pip -y
...
Apptainer> python3 -m pip install numpy
...
Apptainer> exit

[korisnik@x3000c0s27b0n0 korisnik]$ apptainer build pip.sif pip/
```

- 1) Spoji se na pristupni GPU poslužitelj
- 2) Pomakni se u direktorij za izgradnju
- 3) Napravi korisnički direktorij i pomakni se
- 4) Napravi sandbox kontejner s Ubuntu 22.04 OS-om
- 5) Otvori interaktivnu sjednicu
- 6) Osvježi repozitorije
- 7) Nadogradi OS
- 8) Instaliraj python i pip
- 9) Instaliraj pip knjižnicu
- 10) Izadi iz interaktivne sjednice
- 11) Prebaci iz sandbox direktorija u image

Kod 3 Primjer izgradnje kontejnera na Supeku

Apptainer i kontejneri

Izgradnja jednostavnog kontejnera iz definicijske .def datoteke

```
Bootstrap: docker
From: ubuntu:22.04
```

```
%post
```

```
# Ažuriranje OS-a
```

```
apt update -y
```

```
apt upgrade -y
```

```
# Instalacija Pythona i pip modula
```

```
apt install -y python3-pip
```

```
# Instaliraj numpy
```

```
python3 -m pip install numpy
```

1) Preuzmi s DockerHuba...

2) ... Ubuntu verziju 22.04

3) Osvježavanje repozitorija

4) Nadogradnja OS-a

5) Instalacija Pythona i pipa

6) Instalacija Python paketa

Kod 4 Primjer izgradnje kontejnera korištenjem definicijske datoteke na Supeku



Europska unija
"Zajedno do fondova EU"



EUROPSKI STRUKTURNI
I INVESTICIJSKI FONDŃOVI



Operativni program
KONKURENTNOST
I KOHEZIJA

Projekt je sufinancirala Europska unija iz
Europskog fonda za regionalni razvoj.



Apptainer i kontejneri

`> ~/tutorial/6_apptainer/run.sh`

Korištenje kontejnera u PBS skripti

```
#PBS -q cpu
```

```
cd ${PBS_O_WORKDIR}
```

```
apptainer exec pip.sif python3 input.py
```

- 1) Definiranje reda
- 2) Premještanje u radni direktorij
- 3) Pokretanje python skripte putem kontejnera

Kod 5 Primjer skripte PBS za pokretanje kontejnera



Europska unija
"Zajedno do fondova EU"



EUROPSKI STRUKTURNI
I INVESTICIJSKI FONDŌVI



Operativni program
KONKURENTNOST
I KOHEZIJA

Projekt je sufinancirala Europska unija iz
Europskog fonda za regionalni razvoj.



Strojno učenje na Supeku



Europska unija
"Zajedno do fondova EU"



EUROPSKI STRUKTURNI
I INVESTICIJSKI FONDovi



Operativni program
KONKURENTNOST
I KOHEZIJA

Projekt je sufinancirala Europska unija iz
Europskog fonda za regionalni razvoj.

Strojno učenje na Supeku

Aplikacije

- NVIDIA NGC
 - kontejneri optimizirani za izvođenje na GPU
- Dostupne aplikacije
 - Tensorflow 2.10.1
 - PyTorch 1.8.0, 1.14.0 i 2.0.0
 - Dask 2023.7.0
 - Scikit-learn 0.24.1-2, 1.2.2, 1.30
 - Ray 2.4.0
- U izradi
 - Horovod
 - Rapids
 - Lightning AI



Slika 7 Trenutni repertoar knjižnica za strojno učenje



Strojno učenje na Supeku

Resnet50 performanse

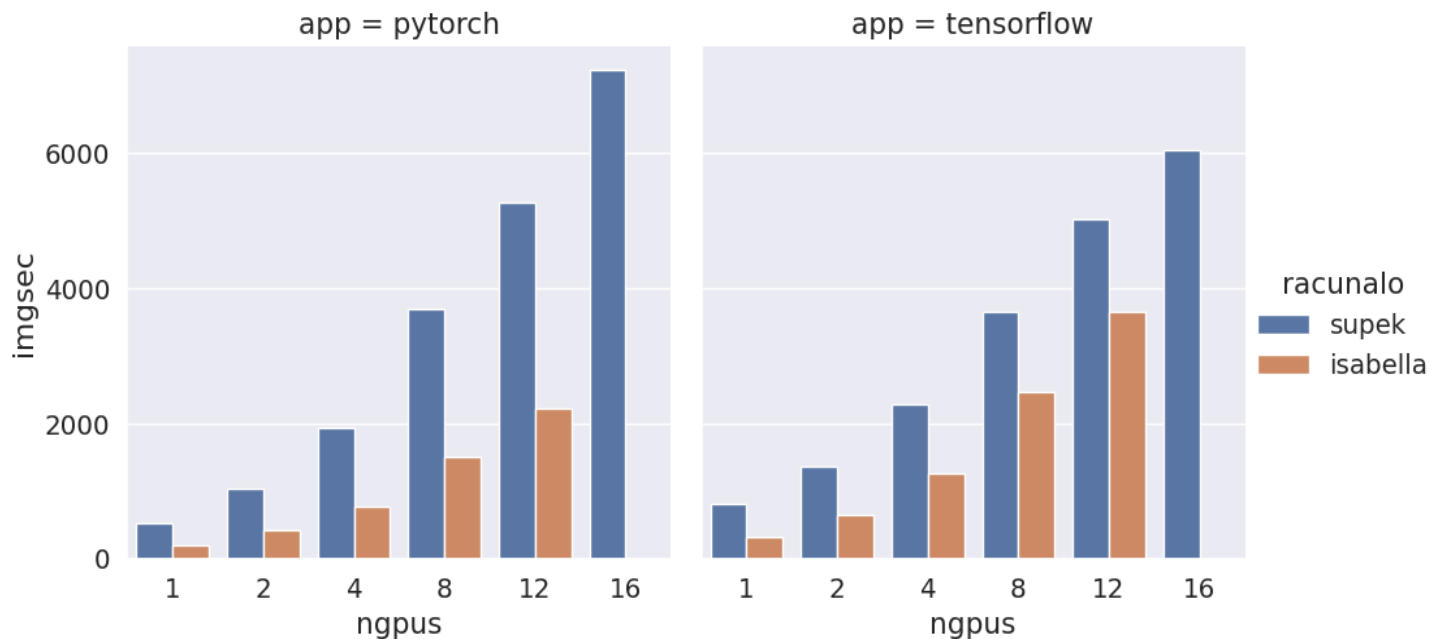

Slika 8 Brzina treniranja modela ResNet50 [img/sec] korištenjem PyTorch a (lijevo) i TensorFlow a (desno) na klasteru Supek (plavo) i Isabella (narančasto)



Strojno učenje na Supeku

Implementacija

- Modulefiles
 - `$IMAGE_PATH` - definicija staze kontejnera
 - `$PATH` - dodavanje wrappera
- Wrapperi
 - Izvršne shell skripte koje osiguravaju integraciju s PBS-om
- Više inačica ovisno o potrebama
 - `run-singlenode.sh` – Tensorflow na jednom čvoru
 - `torchrun-multinode.sh` – PyTorch torchrun na više čvorova
 - `dask-launcher.sh` – Dask općenito



Strojno učenje na Supeku

NCCL – Nvidia Collective Communications Library

- "Data parallel" problem *
 - Usklađivanje gradijenata na više čvorova/procesora
- NCCL
 - NVIDIA MPI
 - NVLink – 600GB/s
- AllReduce
 - Ring & Tree **

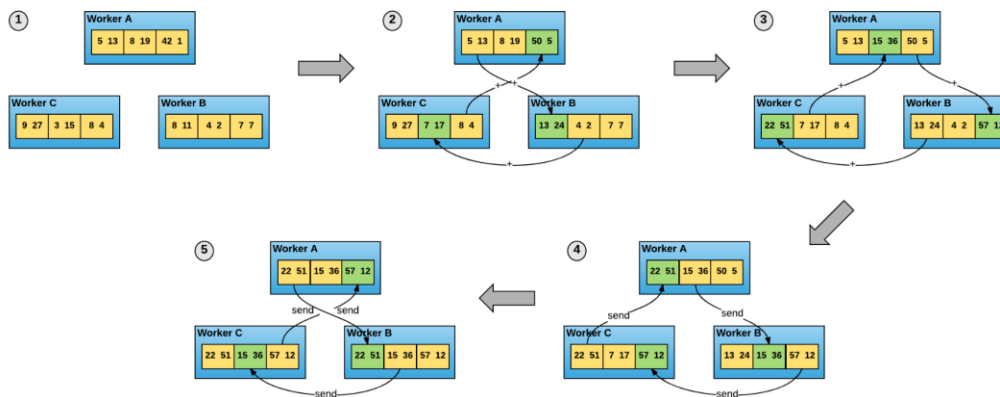

Slika 9 Ring AllReduce algoritam (Figure 4. u izvoru)

* <https://siboehm.com/articles/22/data-parallel-training>

** <https://marek.ai/allreduce-the-basis-of-multi-device-communication-for-neural-network-training.html>



Primjeri



Projekt je sufinancirala Europska unija iz
Europskog fonda za regionalni razvoj.

Primjeri

Priprema

- Primjeri
 - Tensorflow i PyTorch
 - single GPU
 - multi GPU
 - Scikit-learn
 - Xgboost
 - Xgboost & Dask
 - Xgboost & Dask**2
 - Ray
 - PyTorch Train
 - TensorFlow Tune
- Priprema/git
 - [mkvakic-srce/fer-20231006](https://github.com/mkvakic-srce/fer-20231006)

```
[korisnik@x3000c0s25b0n0 ~]$ git clone git@github.com:mkvakic-srce/fer-20231006.git
Cloning into 'fer-20231006'...
remote: Enumerating objects: 70, done.
remote: Counting objects: 100% (70/70), done.
remote: Compressing objects: 100% (44/44), done.
remote: Total 70 (delta 38), reused 58 (delta 26), pack-reused 0
Receiving objects: 100% (70/70), 11.26 KiB | 2.25 MiB/s, done.
Resolving deltas: 100% (38/38), done.

[korisnik@x3000c0s25b0n0 ~]$ cd fer-20231006

[mkvakic@x3000c0s25b0n0 fer-20231006]$ ls -l
README.md
pytorch_distributed.py
pytorch_distributed.sh
pytorch_ray_train.py
pytorch_ray_train.sh
pytorch_singlegpu.py
pytorch_singlegpu.sh
...
```

Kod 6 Priprema direktorija s primjerima korištenjem komande git

Primjeri

TensorFlow

- Zadano ponašanje - 1 GPU
- Distribuirani proračun
 - korištenjem "strategija"
 - Kompajliranje modela unutar djelokruga (*scopea*) strategije
- Strategije
 - **OneDeviceStrategy**
 - **MirroredStrategy**
 - **MultiWorkerMirroredStrategy**
- Podaci se dijele među procesorima

```
...  
layers = [tf.keras.Input(10),  
          tf.keras.layers.Dense(10),  
          tf.keras.layers.Softmax()]  
  
model = tf.keras.Sequential(layers)  
  
strategy = tf.distribute.MirroredStrategy()  
  
with strategy.scope():  
    model.compile()  
  
model.fit(data)  
...
```

- 1) Slojevi
- 2) Model
- 3) Strategija
- 4) Djelokrug
- 5) Kompiliranje
- 6) Treniranje

Kod 7 Priprema TensorFlow modela sa strategijom **MirroredStrategy**

Primjeri

 ~/fer-20231006/tensorflow-singlegpu.*

TensorFlow na jednom GPU procesoru

```
#PBS -q gpu
#PBS -l ngpus=1

module load scientific/tensorflow

cd ${PBS_O_WORKDIR:-""}

run-singlenode.sh tensorflow-singlegpu.py
```

Kod 8 Primjer skripte PBS tensorflow-singlegpu.sh

- 1) Definiranje reda
- 2) Definiranje resursa
- 3) Doplemanje TensorFlowa
- 4) Pomicanje u radni direktorij
- 5) Pokretanje python skripte putem wrappera

Primjeri

 ~/fer-20231006/tensorflow-strategy.*

TensorFlow na više GPU procesora

```
#PBS -q gpu
#PBS -l select=2:ngpus=1

module load scientific/tensorflow

cd ${PBS_O_WORKDIR:-""}

run-multinode.sh tensorflow-strategy.py
```

Kod 9 Primjer skripte PBS tensorflow-strategy.sh

- 1) Definiranje reda
- 2) Definiranje resursa
- 3) Doplemanje TensorFlowa
- 4) Pomicanje u radni direktorij
- 5) Pokretanje python skripte putem wrappera

Primjeri

PyTorch

- Ručno postavljanje na dostupne procesore (rangove)
- torchrun
 - izvorno sučelje
 - implementacija slična MPI
- accelerate
 - HuggingFace sučelje
 - viši nivo apstrakcije

```
...  
torch.distributed.init_process_group('nccl')  
local_rank = int(os.environ['LOCAL_RANK'])  
  
model = torchvision.models.resnet50()  
model = model.to(local_rank)  
  
for input, output in dataloader:  
    optimizer.zero_grad()  
    predicted = model(input)  
    loss = loss_fn(predicted, output)  
    loss.backward()  
    optimizer.step()  
...
```

- 1) Inicijalizacija
- 2) Definiraj lokalni rang
- 3) Model
- 4) Postavi na lokalni rang
- 5) Treniraj

Kod 10 Priprema PyTorch modela sa torchrun



Europska unija
"Zajedno do fondova EU"



EUROPSKI STRUKTURNI
I INVESTICIJSKI FONDovi



Operativni program
KONKURENTNOST
I KOHEZIJA

Projekt je sufinancirala Europska unija iz
Europskog fonda za regionalni razvoj.

Primjeri

 ~/fer-20231006/pytorch-singlegpu.*

PyTorch na jednom GPU procesoru

```
#PBS -q gpu
#PBS -l ngpus=1

module load scientific/pytorch

cd ${PBS_O_WORKDIR:-""}

run-singlegpu.sh pytorch-singlegpu.py
```

- 1) Definiranje reda
- 2) Definiranje resursa
- 3) Dopremanje PyTorch-a
- 4) Pomicanje u radni direktorij
- 5) Pokretanje python skripte putem wrappera

Kod 11 Primjer skripte PBS pytorch-singlegpu.sh



Europska unija
"Zajedno do fondova EU"



EUROPSKI STRUČNI
I INVESTICIJSKI FONDŌVI



Operativni program
KONKURENTNOST
I KOHEZIJA

Projekt je sufinancirala Europska unija iz
Europskog fonda za regionalni razvoj.

Primjeri

 ~/fer-20231006/pytorch-torchrun.*

PyTorch na više GPU procesora

```
#PBS -q gpu
#PBS -l select=2:ngpus=1

module load scientific/pytorch

cd ${PBS_O_WORKDIR:-""}

torchrun-multinode.sh pytorch-torchrun.py
```

- 1) Definiranje reda
- 2) Definiranje resursa
- 3) Dopremanje PyTorch-a
- 4) Pomicanje u radni direktorij
- 5) Pokretanje python skripte putem wrappera

Kod 12 Primjer skripte PBS `pytorch-torchrun.sh`



Europska unija
"Zajedno do fondova EU"



EUROPSKI STRUKTURNI
I INVESTICIJSKI FONDovi



Operativni program
KONKURENTNOST
I KOHEZIJA

Projekt je sufinancirala Europska unija iz
Europskog fonda za regionalni razvoj.



Primjeri

Dask

- Namijenjeno paralelizaciji Python koda i distribuiranoj obradi OOM podataka
- Razlaganje programa na jednostavne operacije korištenjem **dask** grafova
- Komponente
 - Array – tenzori
 - DataFrame – strukturirani podaci
 - Bag – nizovi
 - Delayed – custom funkcije
 - Futures – eager Delayed

Collections

(create task graphs)

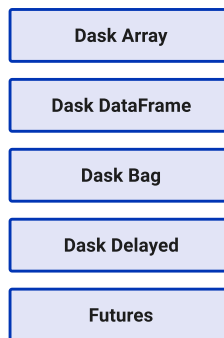

Task Graph

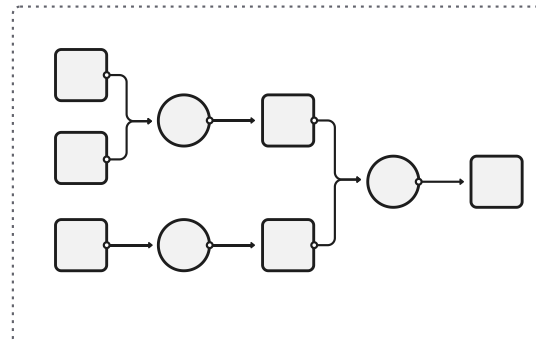

Schedulers

(execute task graphs)

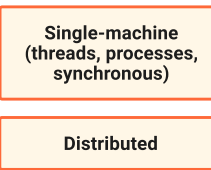

Slika 10 Shema aplikacije na klasteru Dask ([izvor](#))



Primjeri

Dask grafovi

```
def inc(i):  
    return i + 1
```

```
def add(a, b):  
    return a + b
```

```
x = 1  
y = inc(x)  
z = add(y, 10)
```

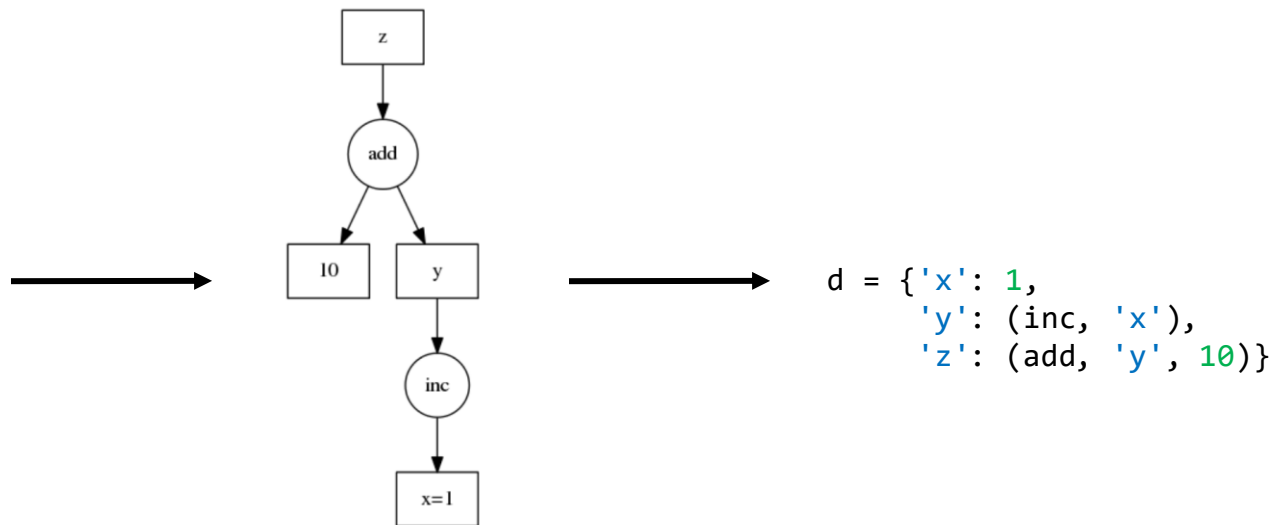

```
d = {'x': 1,  
      'y': (inc, 'x'),  
      'z': (add, 'y', 10)}
```

Slika 11 Osnovni graf Dask (Fig 1. u [izvoru](#))

Primjeri

Dask Array

```
>>> import dask.array as da

>>> x = da.arange(15, chunks=(5))
>>> x.dask
{('x', 0): (np.arange, 0, 5),
 ('x', 1): (np.arange, 5, 10),
 ('x', 2): (np.arange, 10, 15)}

>>> z = (x + 100).sum()
>>> z.dask
{('x', 0): (np.arange, 0, 5),
 ('x', 1): (np.arange, 5, 10),
 ('x', 2): (np.arange, 10, 15),
 ('y', 0): (add, ('x', 0), 100),
 ('y', 1): (add, ('x', 1), 100),
 ('y', 2): (add, ('x', 2), 100),
 ('z', 0): (np.sum, ('y', 0)),
 ('z', 1): (np.sum, ('y', 1)),
 ('z', 2): (np.sum, ('y', 2)),
 ('z',): (sum, [('z', 0), ('z', 1), ('z', 2)])}

>>> z.compute()
1605
```

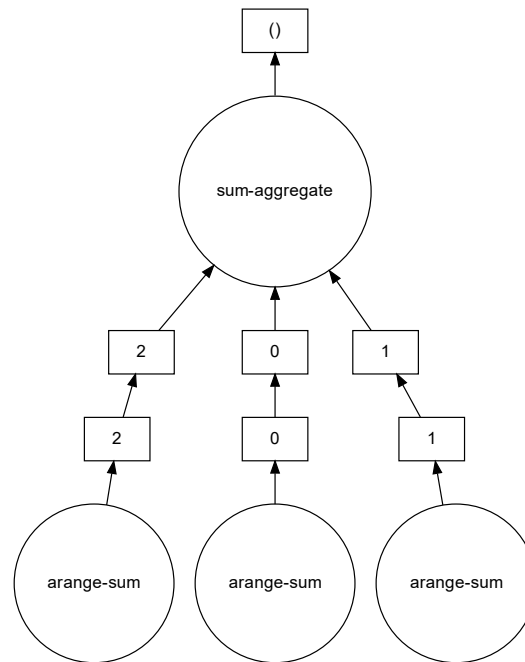

Slika 12 Dask Array i operacija zbrajanja u obliku grafa (Example: arange u [izvoru](#))





Primjeri

Dask OOM podaci

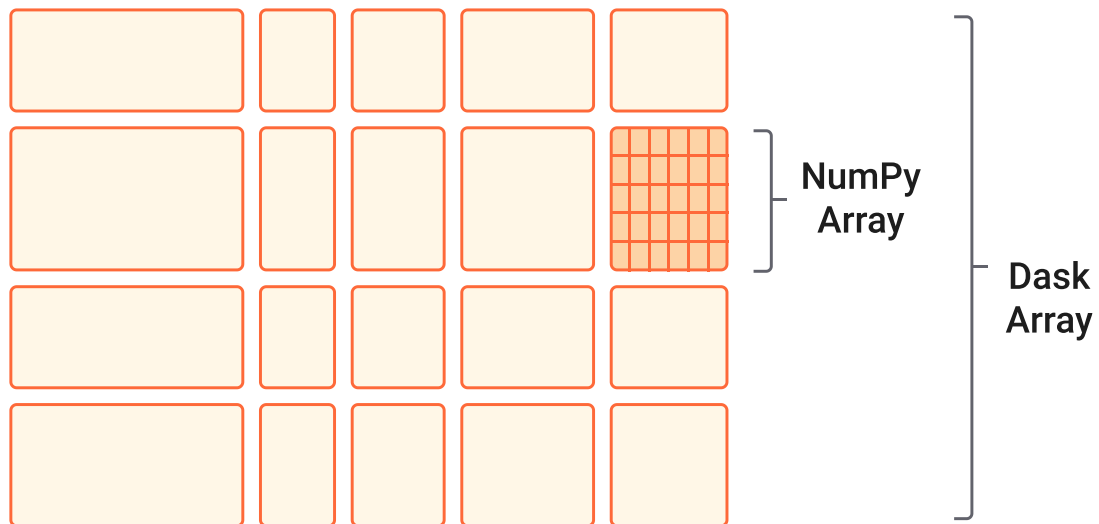

Slika 13 Distribucija podataka na klasteru Dask u slučaju Dask Arraya ([izvor](#))

Primjeri

 ~/fer-20231006/sklearn-threads.*

Scikit-learn putem multi-threadinga

```
#PBS -q cpu
#PBS -l select=1:ncpus=16

module load scientific/dask

cd ${PBS_O_WORKDIR:-""}

$IMAGE_PATH python sklearn-threads.py
```

Kod 13 Primjer skripte PBS sklearn-threads.sh

- 1) Definiranje reda
- 2) Definiranje resursa
- 3) Doplemanje Daska
- 4) Pomicanje u radni direktorij
- 5) Pokretanje python skripte putem wrappera

Primjeri

 ~/fer-20231006/sklearn-dask.*

Scikit-learn + Dask na više čvorova

```
#PBS -q cpu
#PBS -l select=2:ncpus=16:mem=50GB

module load scientific/dask

cd ${PBS_O_WORKDIR:-""}

dask-launcher.sh sklearn-dask.py
```

Kod 14 Primjer skripte PBS sklearn-dask.sh

- 1) Definiranje reda
- 2) Definiranje resursa
- 3) Doplemanje Daska
- 4) Pomicanje u radni direktorij
- 5) Pokretanje python skripte putem wrappera



Europska unija
"Zajedno do fondova EU"



EUROPSKI STRUKTURNI
I INVESTICIJSKI FONDŌVI



Operativni program
KONKURENTNOST
I KOHEZIJA

Projekt je sufinancirala Europska unija iz
Europskog fonda za regionalni razvoj.

Primjeri

 ~/fer-20231006/sklearn-dask-dask.*

Dask na više čvorova

```
#PBS -q cpu
#PBS -l select=2:ngpus=1

module load scientific/dask

cd ${PBS_O_WORKDIR:-""}

dask-launcher.sh sklearn-dask-dask.py
```

Kod 15 Primjer skripte PBS sklearn-dask-dask.sh

- 1) Definiranje reda
- 2) Definiranje resursa
- 3) Dopremanje Daska
- 4) Pomicanje u radni direktorij
- 5) Pokretanje python skripte putem wrappera



Primjeri

Ray

- Originalno
 - Distribuirano ojačano učenje
- Komponente
 - Ray Core – osnovne elementi
 - Ray Air – distribucija ML
 - Ray Ecosystem – prilagodba postojećim knjižnicama ML
- Osnovni elementi – Ray Core
 - Tasks – funkcije
 - Actors – klase
 - Objects – varijable

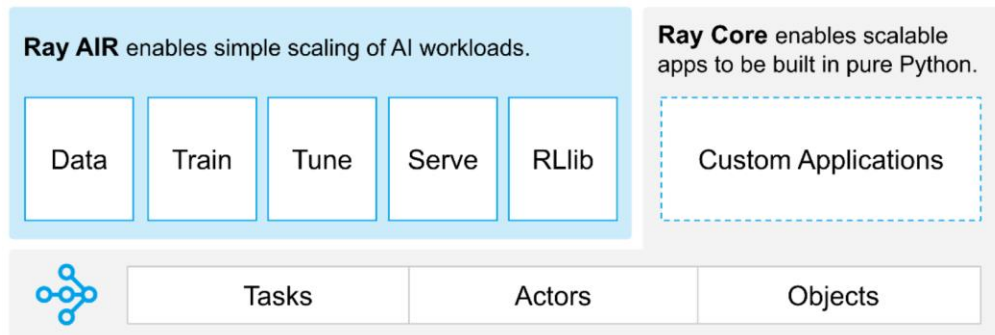

Slika 14 Ray komponente ([izvor](#))

Primjeri

Ray klasteri

- Head čvor
 - Driver – glavni program
 - Global Control Store – koordinacija klastera
- Worker čvorovi
 - Worker – izvršavanje zadataka i "posjedovanje" referenci
- Raylet
 - koordinacija lokalnih resursa
 - Scheduler – raspoređivanje
 - Object Store – pohrana

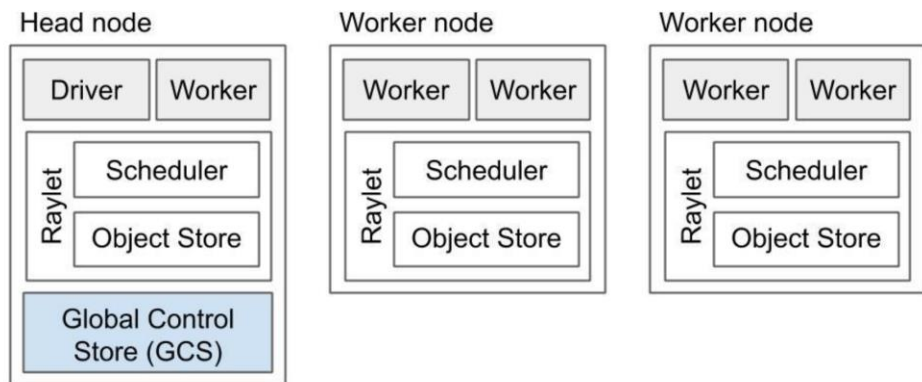

Slika 15 Shema Ray klastera (Figure 2-3 u [izvoru](#))



Primjeri

Ray reference i izvođenje programa

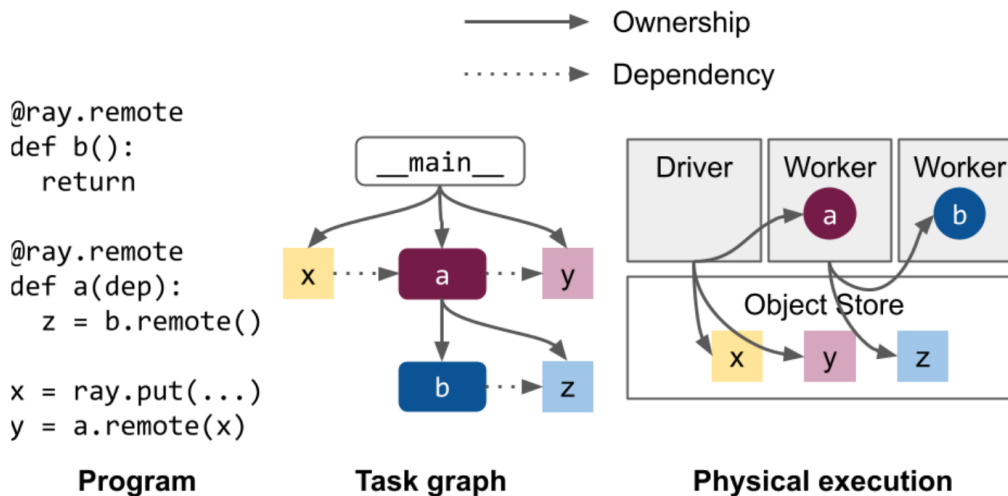

Slika 16 Shema Ray posjedovanja i izvršavanja (*Ownership*, str. 8 u [izvoru](#))



Primjeri

 ~/fer-20231006/pytorch-ray-train.*

PyTorch putem Ray Traina

```
#PBS -q gpu
#PBS -l select=2:ngpus=1:ncpus=4

module load scientific/ray

cd ${PBS_O_WORKDIR:-""}

ray-launcher.sh pytorch-ray-train.py
```

Kod 16 Primjer skripte PBS pytorch-ray-train.sh

- 1) Definiranje reda
- 2) Definiranje resursa
- 3) Doplemanje Raya
- 4) Pomicanje u radni direktorij
- 5) Pokretanje python skripte putem wrappera



Primjeri

 ~/fer-20231006/tensorflow-ray-tune.*

TensorFlow putem Ray Tunea

```
#PBS -q gpu
#PBS -l select=2:ngpus=1:ncpus=4

module load scientific/ray

cd ${PBS_O_WORKDIR:-""}

ray-launcher.sh tensorflow-ray-tune.py
```

Kod 17 Primjer skripte PBS tensorflow-ray-tune.sh

- 1) Definiranje reda
- 2) Definiranje resursa
- 3) Doplemanje Raya
- 4) Pomicanje u radni direktorij
- 5) Pokretanje python skripte putem wrappera



Hvala na pažnji!



Projekt je sufinancirala Europska unija iz
Europskog fonda za regionalni razvoj.